

Mantis® Compost-Twin™

OWNER'S MANUAL



Welcome To The World Of Mantis Gardening!

Here's your new Mantis CompostT-Twin...the unique dual-chamber composter that will make gardening easier for you.

With your new CompostT-Twin, you'll always have a place to throw your kitchen scraps, leaves and grass clippings...and you'll have a constant supply of the rich, nutrient-filled compost your garden loves.

Once you know how to assemble and use your CompostT-Twin correctly, we guarantee you'll love it. So first, please read this manual and watch the enclosed assembly video. They show, step by step, how to assemble your machine and how to get the best results.



Table of Contents

Safety Rules & Warnings	2
Safety Decals	3
Box Contents	4
Support Frame Assembly	6
Support Frame Assembly Layout	7
Support Frame Parts List	8
Drum Parts List	12
Drum Assembly Layout	13
Drum Assembly	14
Maintenance Instructions	21
Using your CompostT-Twin	22
The Right Mix of Materials	23
Using Compost	25
Troubleshooting Tips	26
Limited Warranty Information	28

Safety Rules & Warnings

You will notice throughout this Owner's Manual Safety Rules and Important Notes. Make sure you understand and obey these warnings for your own protection.

SAFETY WARNING

ATTENTION: THIS SYMBOL POINTS OUT OUR IMPORTANT SAFETY INSTRUCTIONS. TO REDUCE THE POTENTIAL FOR ACCIDENTS, COMPLY WITH THE SAFETY INSTRUCTIONS IN THIS MANUAL.

Safety Decal Identification

An important part of the safety system incorporated in this composter is the information decal found on the door of the composter. This decal must be replaced in time; it is your responsibility to replace this decal when it becomes hard to read. The location of this decal, part number (P/N 200600), is illustrated on page 4.

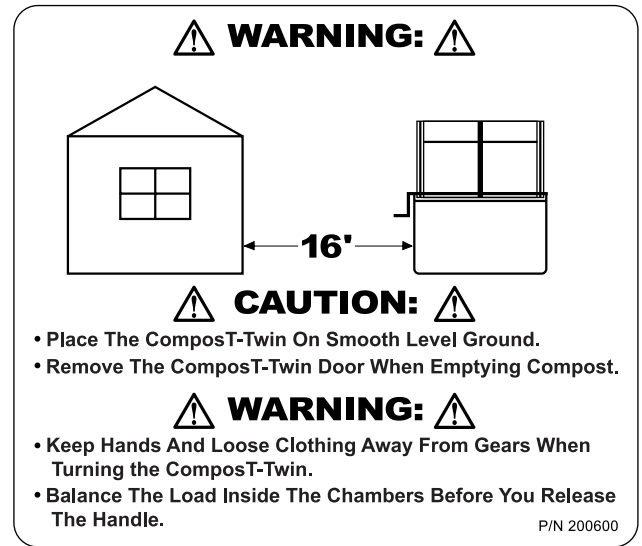

Warnings

- Check and tighten all of the 2" bolts (part no. 200500) on the frame assembly every two months.
- Keep children away from the ComposT-Twin.
- Remove the drum from the frame before relocating the unit.
- **Do not** overload the ComposT-Twin. Maximum load is 600 pounds.

Mantis Customer Service

If you have any difficulty following the assembly instructions, contact your local authorized Mantis Dealer where you purchased the ComposT-Twin for assistance.





Box Contents

All of the ComposT-Twin parts, including sheet metal, frame tubing, plastic end caps, and hardware, are packed in three boxes. Refer to the diagrams below for the contents of each box.

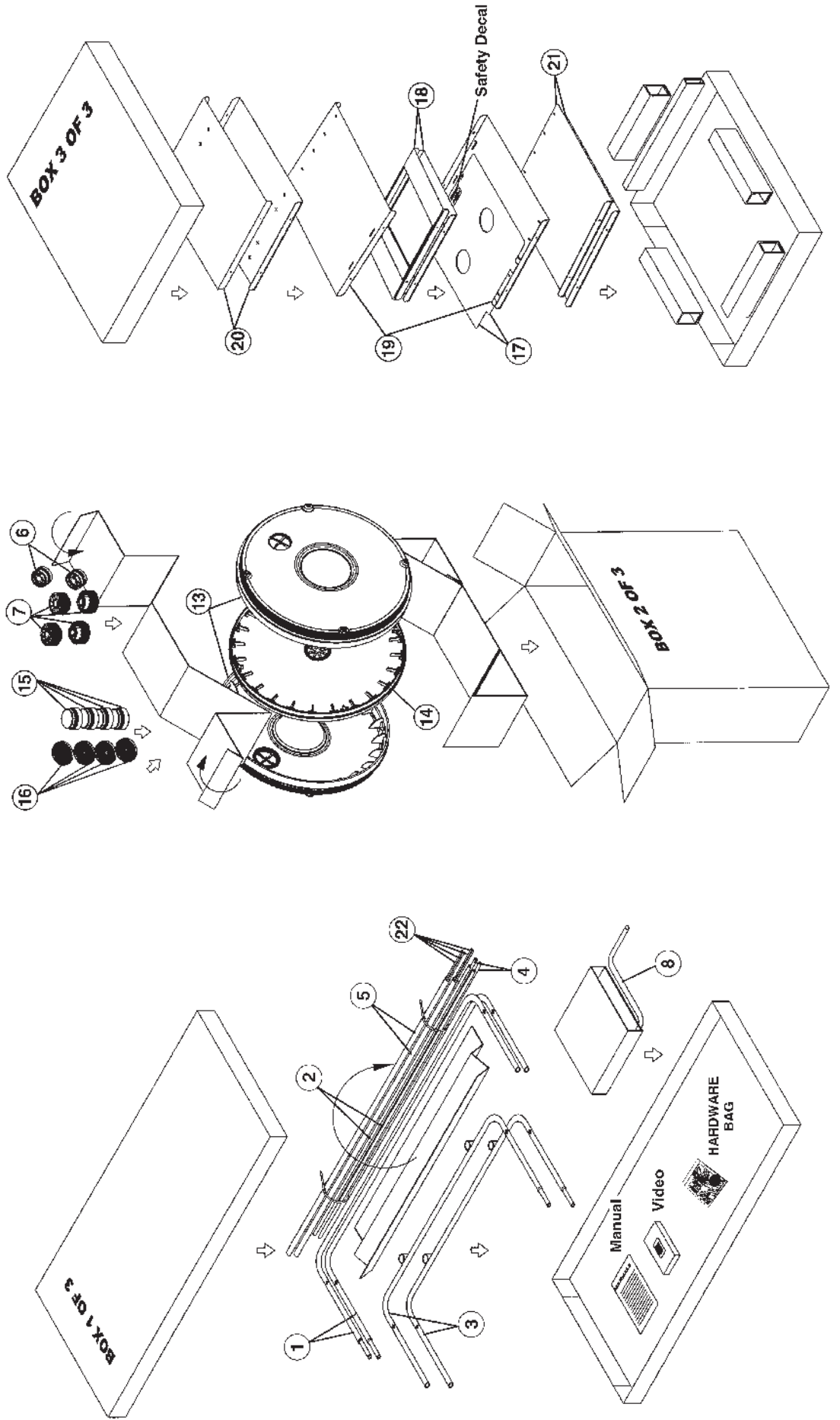

Large Parts, Boxes 1-3

KEY #	DESCRIPTION	QTY	PART #	ASSEMBLY
1	"C" shaped lower support	2	200100	Frame
2	Short spacer (lower support)	2	200101	Frame
3	Upper support with axle rod guides	2	200102	Frame
4	Long spacer (upper support)	2	200103	Frame
5	Axle Rod	2	200115	Frame
6	Center support wheel	2	200107	Frame
7	Gear	4	200105	Frame
8	Handle	1	200108	Frame
13	End cap	2	200204	Drum
14	Divider	1	200201	Drum
15	Breather cap	4	200220	Drum
16	Breather screen	4	200221	Drum
17	Door	2	200207	Drum
18	Door opening, 2nd panel	2	200203	Drum
19	Drum 1st panel	2	200216	Drum
20	Drum 3rd panel	2	200211	Drum
21	Drum 4th panel	2	200224	Drum
22	Threaded rod	4	200202	Drum

Hardware Parts Bag (part #200517)

KEY #	DESCRIPTION	QTY	PART #	ASSEMBLY
9	Plastic grip	1	200109	Frame
10	Push cap nut	1	200110	Frame
11	Spring pin	4	200106	Frame
12	2" long shoulder bolt	8	200500	Frame
23	Mesh screen	2	200222	Drum
24	Latches	4	200223	Drum
25	Acorn nut	8	200504	Drum
26	#8 self-tapping screw (for breather)	4	651	Drum
27	#10 screw	20	200506	Drum
28	#10 flat washer	20	200508	Drum
29	Keps nut	20	200509	Drum
30	#10 shoulder screw	12	200510	Drum
31	#10 nylon insert lock nut	12	200511	Drum
32	1/4" flat washer (for threaded rods)	4	200512	Drum
33	Disposable red protective cover	4	300316	Drum

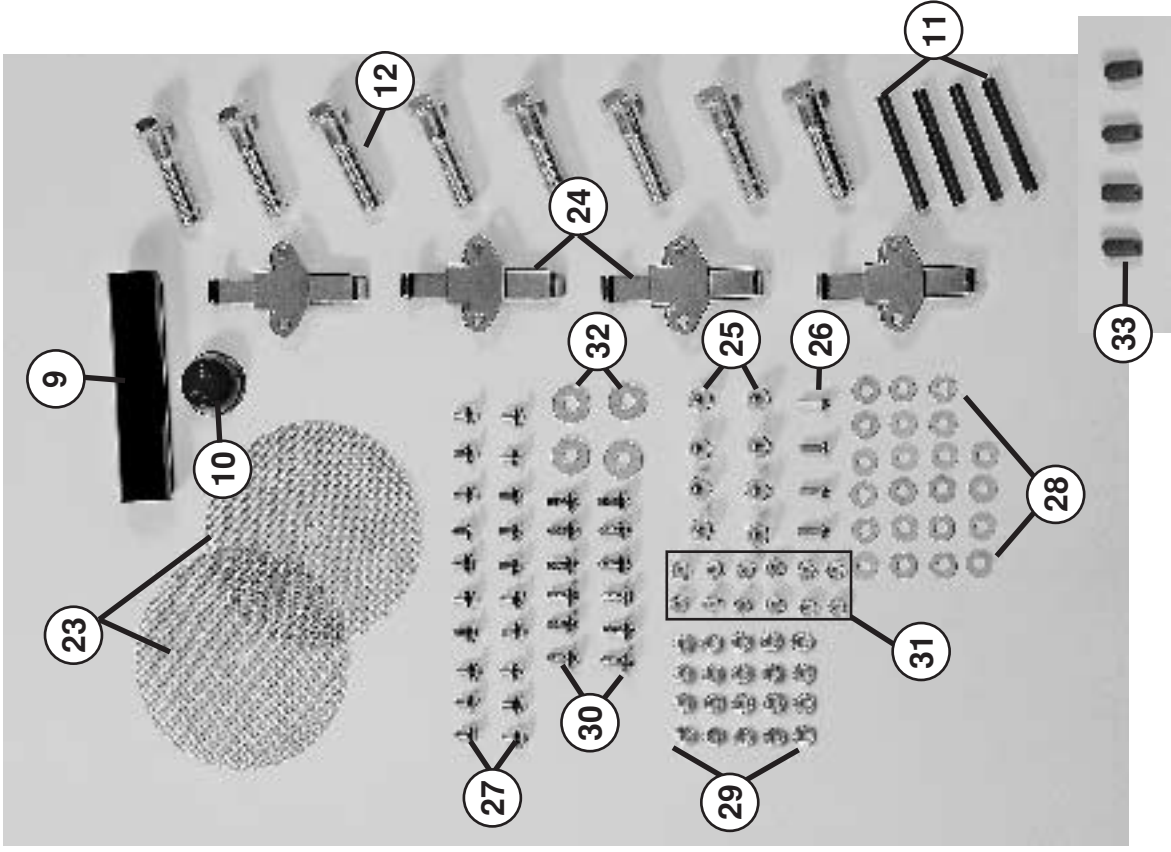



Assembly of the Compost-Twin is divided into two major sub-assemblies:

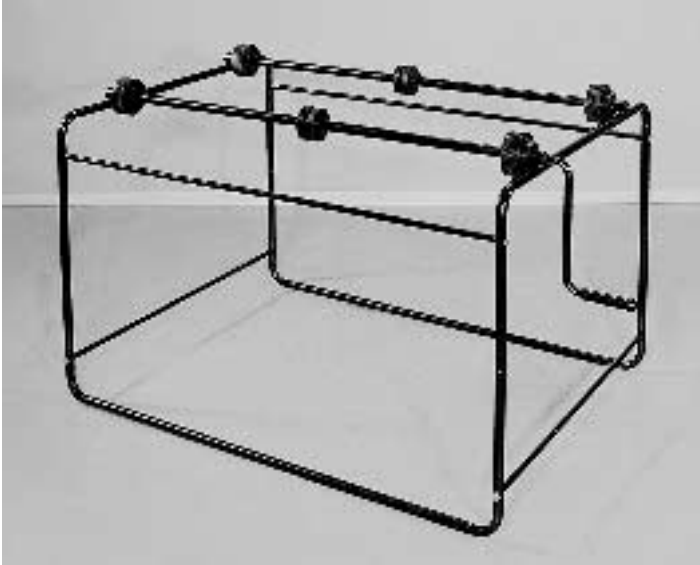

Support frame



Drum

and

Tools needed for assembly of Compost-Twin:

- ✓ Hammer or rubber mallet
- ✓ 3/4" wrench
- ✓ 7/16" wrench
- ✓ 7/16" socket wrench
- ✓ 3/8" wrench
- ✓ Regular screwdriver (flat head)
- ✓ Phillips screwdriver (cross head)
- ✓ Wheel bearing-type grease

The Compost-Twin is easiest to assemble with TWO PEOPLE sharing and coordinating the work. Allow 1-2 hours to assemble the entire composter.

Begin with the Support Frame Assembly.



SAFETY WARNING



THE DIMENSIONS OF THE ASSEMBLED SUPPORT FRAME ARE 35" HIGH X 56" LONG X 41" WIDE. BE SURE TO ASSEMBLE THE SUPPORT FRAME IN A GARAGE OR OPEN AREA WHERE YOU WILL BE ABLE TO MOVE IT EASILY ONCE YOU ARE FINISHED.

Tools needed for Support Frame Assembly:

Hammer or rubber mallet and 3/4" wrench.

Find a large, shaded area outside your house or in your garage to assemble the Support Frame. **DO NOT ASSEMBLE THE SUPPORT FRAME IN YOUR LIVING ROOM, AS YOU WON'T BE ABLE TO GET IT THROUGH THE DOOR WHEN YOU ARE DONE!**



Support Frame Assembly Layout

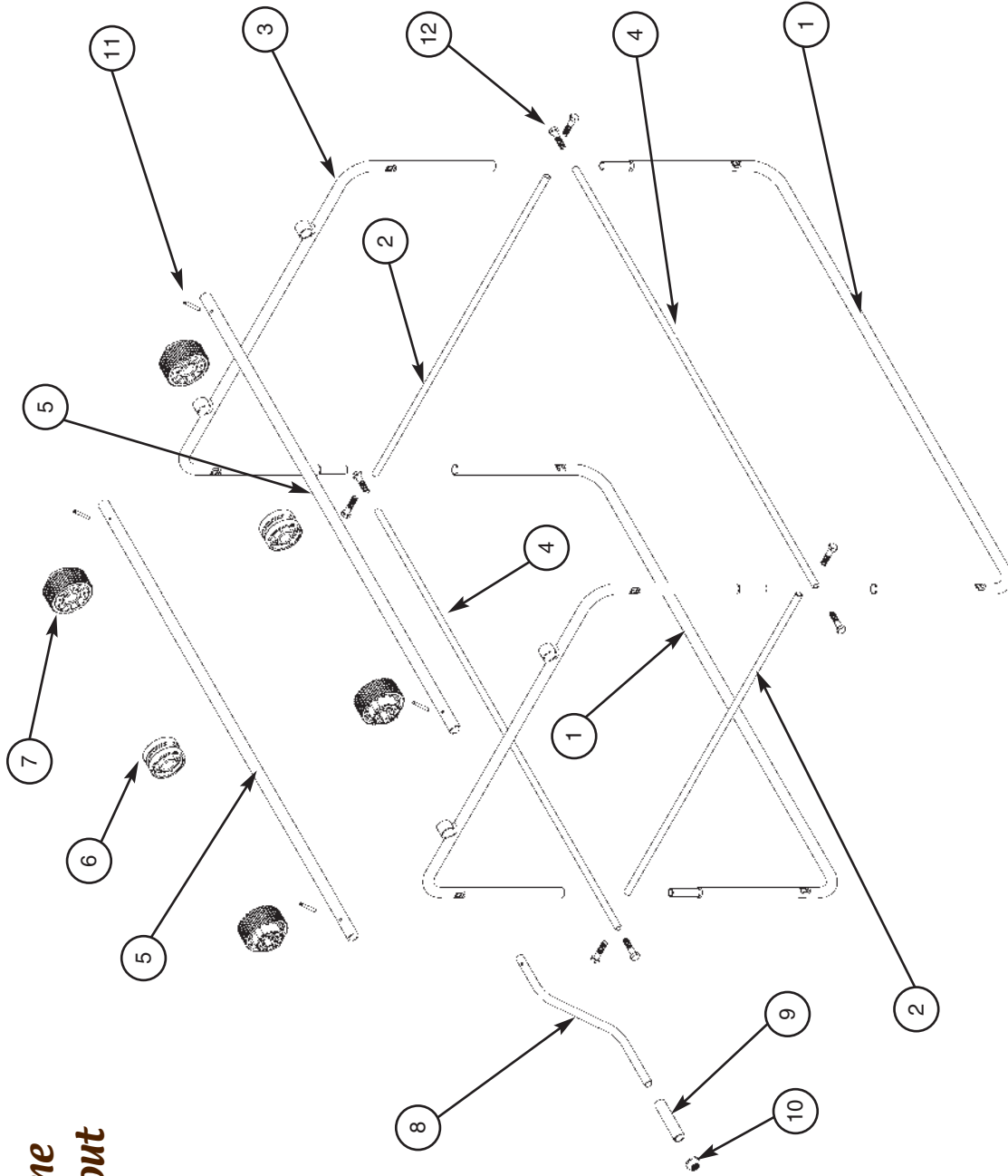

KEY #	DESCRIPTION	QTY	PART #
1	"C" shaped lower support	2	200100
2	Short spacer (lower support)	2	200101
3	Upper support with axle rod guides	2	200102
4	Long spacer (upper support)	2	200103
5	Axle rod	2	200115
6	Center support wheel	2	200107

KEY #	DESCRIPTION	QTY	PART #
7	Gear	4	200105
8	Handle	1	200108
9	Plastic grip	1	200109
10	Push cap nut	1	200110
11	Spring pin	4	200106
12	2" long shoulder bolt	8	200500

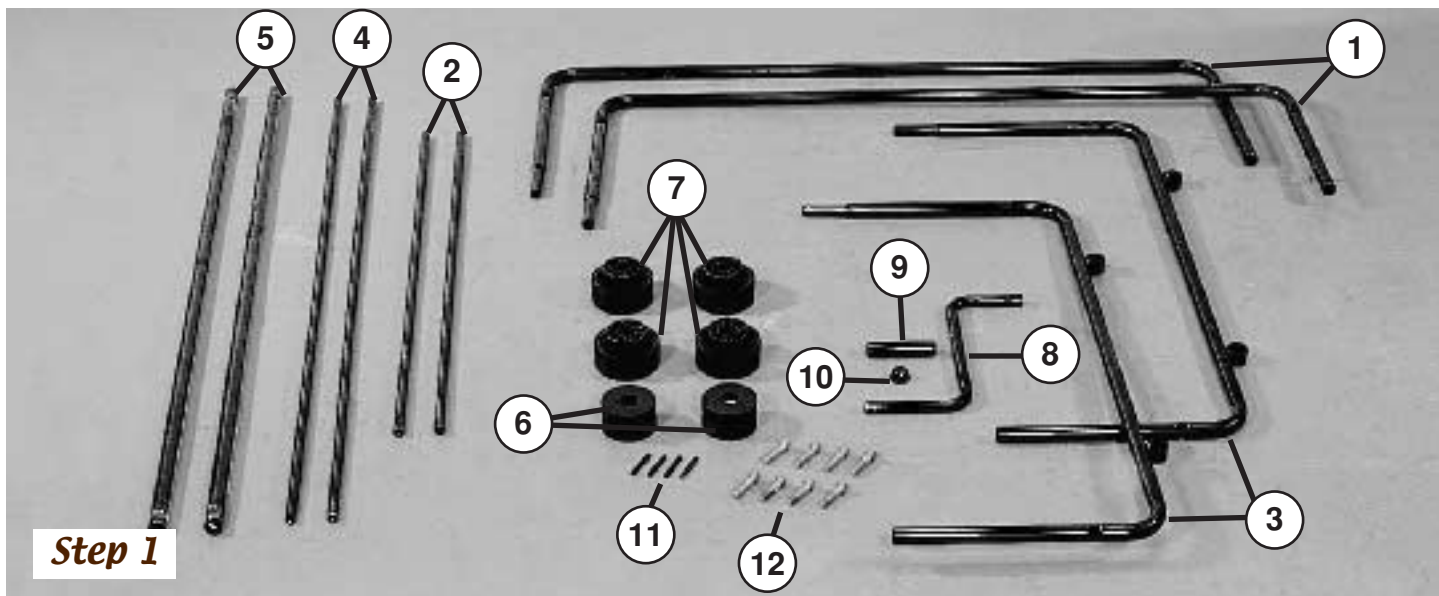

Step 1

Parts for the Support Frame Assembly

Gather the parts you will need to assemble the support frame.

KEY #	DESCRIPTION	QTY	PART #
1	"C" shaped lower support	2	200100
2	Short spacer (lower support)	2	200101
3	Upper support with axle rod guides	2	200102
4	Long spacer (upper support)	2	200103
5	Axle rod	2	200115
6	Center support wheel	2	200107
7	Gear	4	200105
8	Handle	1	200108
9	Plastic grip	1	200109
10	Push cap nut	1	200110
11	Spring pin	4	200106
12	2" long shoulder bolt	8	200500



Step 2

Fasten one end of the short spacer (key #2) to "C" shaped lower support (key #1) with 2" shoulder bolt (key #12). Finger tighten - do not completely tighten nuts and bolts.

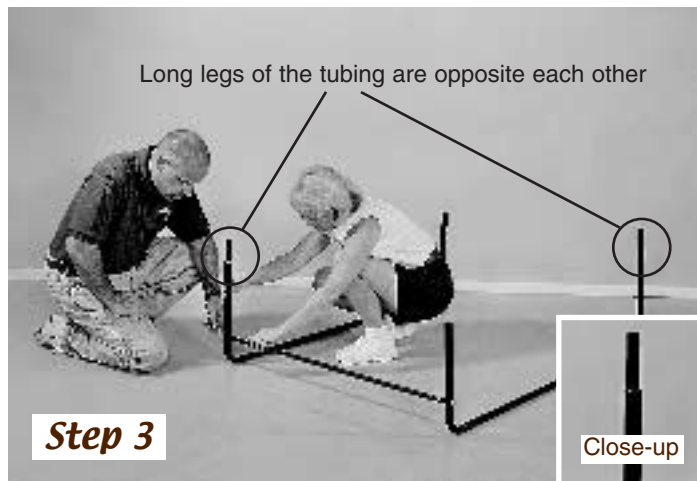

Step 3

Place second "C" shaped lower support in a position where the long legs of the tubing are diagonally opposite each other, as shown. Fasten the other end of the short spacer to the second "C" shaped lower support. Repeat this step on the other side.

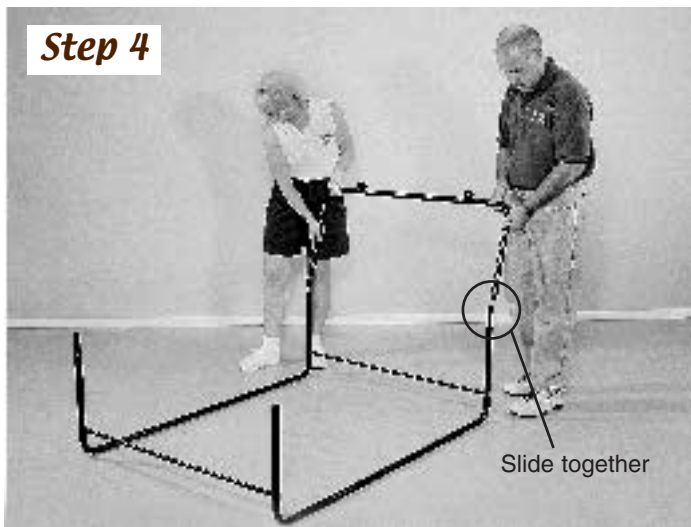

Place upper supports (key #3) in a position where the smaller leg of the upper support slides into the wider leg of the lower support, and the wider leg of the upper support slides into the smaller leg of the lower support, as shown. Slide the ends of the upper support tubing fully into and over the lower support section. Repeat this step on the other end.

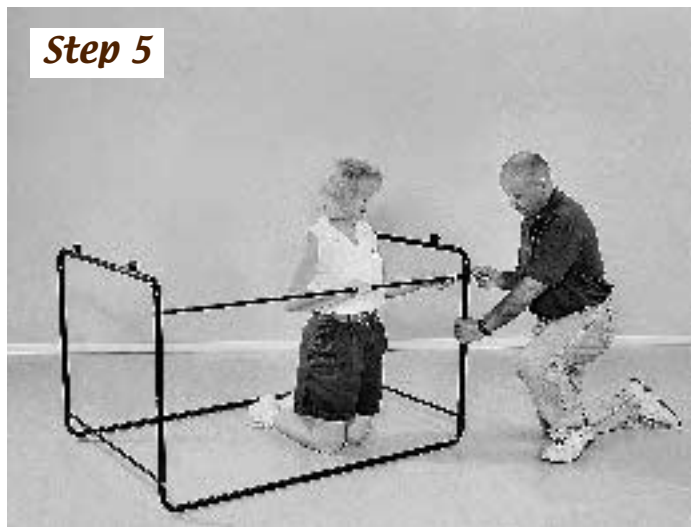

Fasten the long spacers (key #4) to the upper support on both sides using 2" shoulder bolts (key #12). Tighten fully.

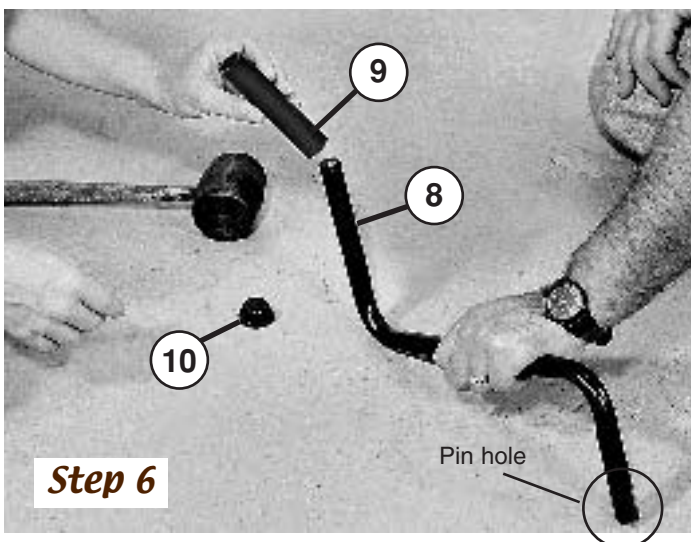

Slide plastic grip (key #9) over the handle (key #8). Be sure that pin hole is on the opposite end of the handle.



Place the push cap nut (key #10) over the handle and tap it on with a hammer or rubber mallet. Put handle assembly aside for now.

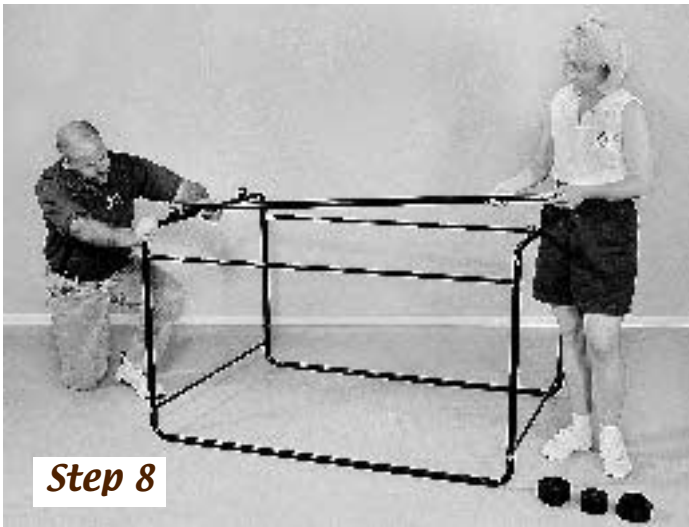

Slide one end of the axle rod (key #5) into the axle rod guide of the upper support assembly.

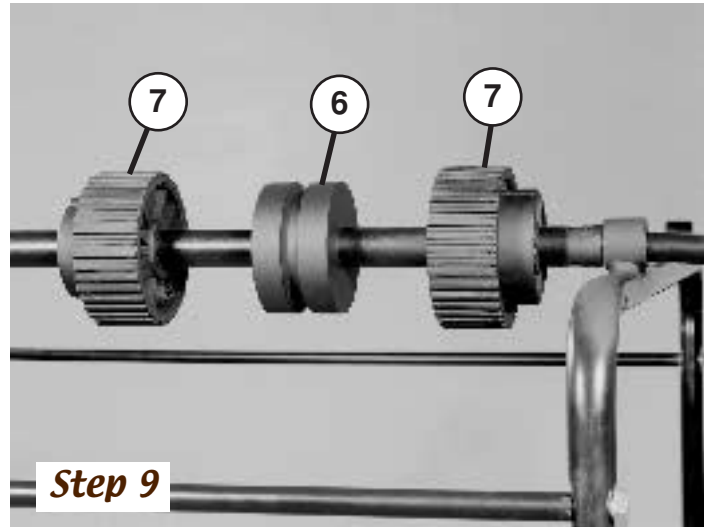

Slide one gear (key #7), one center support wheel (key #6), and another gear onto the axle rod in the order shown.



Slide the other end of the axle rod through the corresponding guide so that the axle rod is supported by the guides.

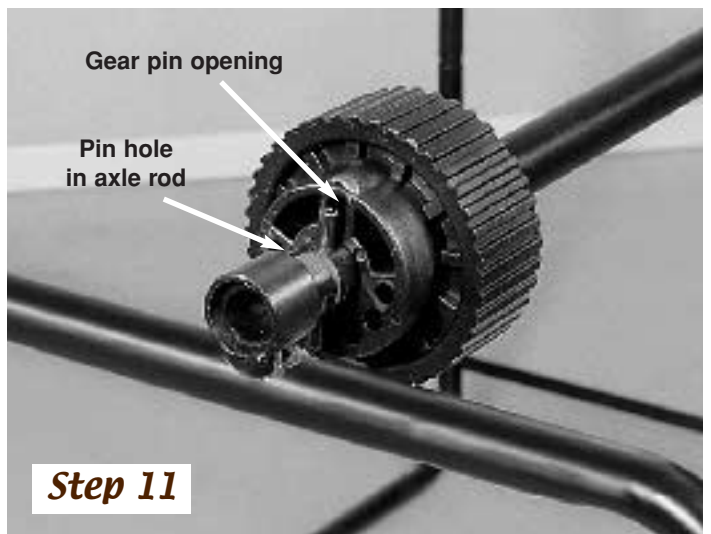

Make sure that the gears pin opening faces the pin hole in the axle rod tubing. Repeat these steps 8-10 for the second axle rod.

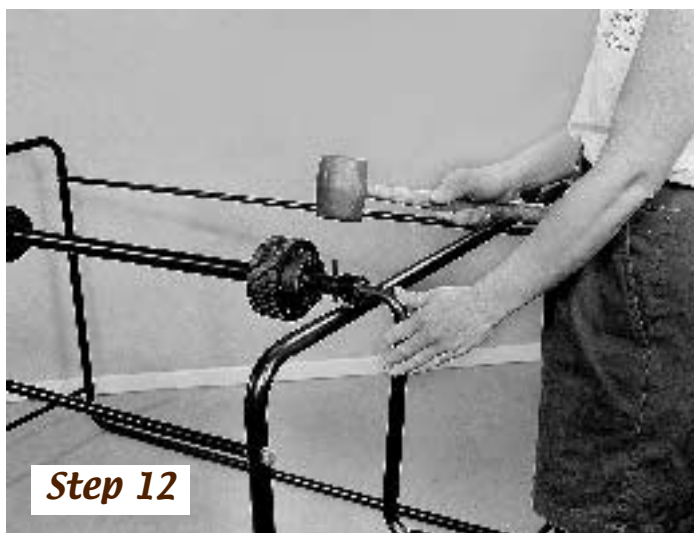

Step 12

Choose the corner for the handle (this decision is entirely a factor of your convenience). Place the end of the handle assembly inside the axle rod at that corner, and align the holes of the handle and axle rod. Gently drive spring pin (key #11) through the holes using a hammer or rubber mallet.

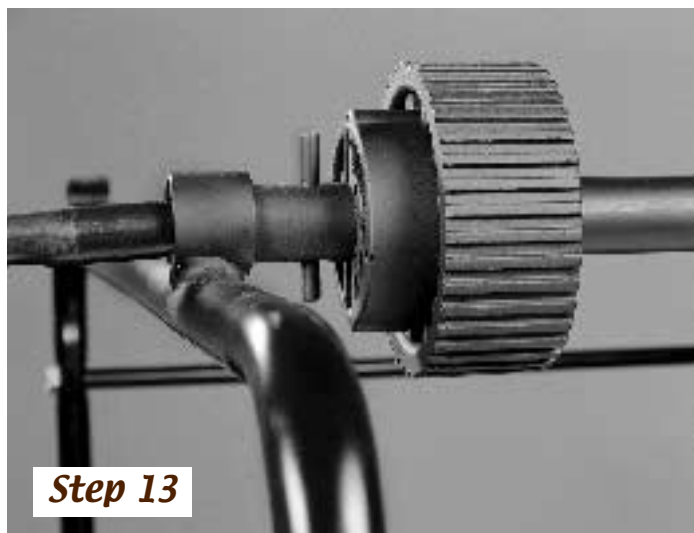

Step 13

Drive the spring pins through the holes in the three other corners of the frame. The spring pin should extend an equal amount on each side of the axle rod. Line up the pin opening in the gear (key #7) with the corresponding pin and slide the gear over it. Repeat this step with each gear. **TIGHTEN ALL NUTS AND BOLTS SECURELY.**

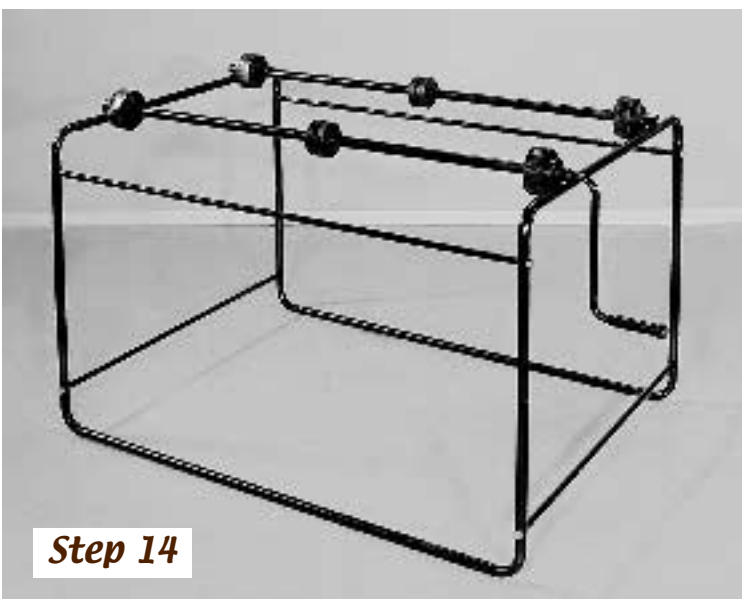

Step 14

The support frame for your Mantis Compost-Twin is ready!

Place the frame on level ground, where you want the composter to be located in your yard. Lubricate the four axle rod guide sections with wheel bearing-type grease.

! SAFETY WARNING !

A SLANTED OR UNEVEN POSITION CAN MAKE THE LOADED COMPOSTER UNSTABLE AND HARDER TO TURN. BE SURE TO PLACE THE SUPPORT FRAME ON LEVEL GROUND

Now, you will assemble the Compost-Twin Drum:

Tools needed for Drum Assembly:

3/8" wrench

7/16" wrench

7/16" socket wrench

Regular screwdriver (flat head)

Phillips screwdriver (cross head)

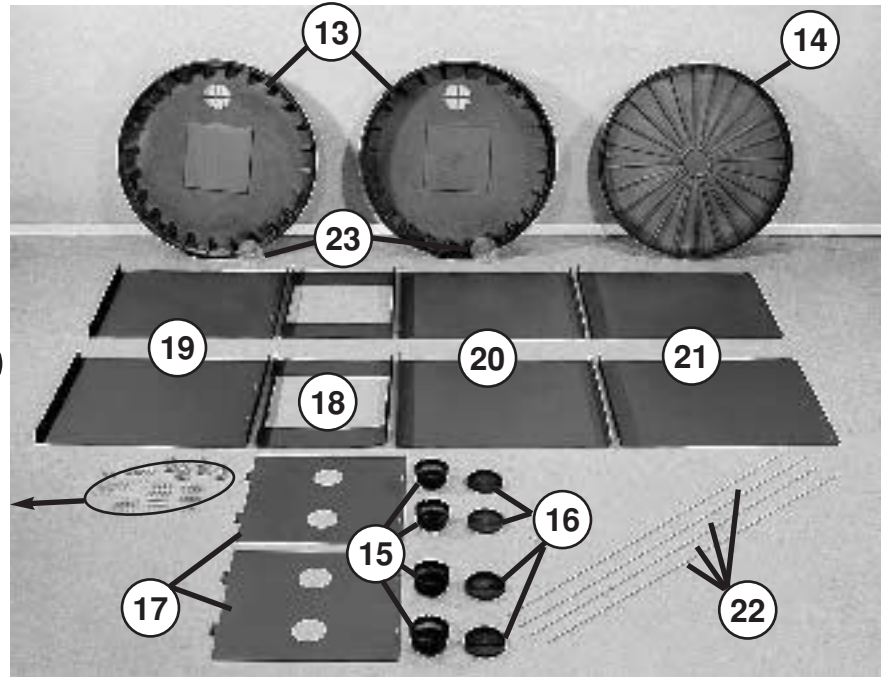
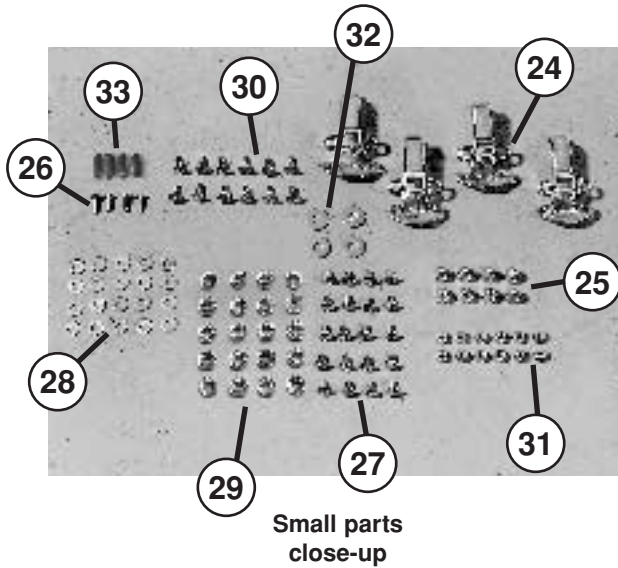

Parts for the Drum Assembly

Gather the parts you will need to assemble the Compost-Twin drum.

KEY #	DESCRIPTION	QTY	PART #
13	End cap	2	200204
14	Divider	1	200201
15	Breather cap	4	200220
16	Breather screen	4	200221
17	Door	2	200207
18	Door opening, 2nd panel	2	200203
19	Drum 1st panel	2	200216
20	Drum 3rd panel	2	200211
21	Drum 4th panel	2	200224
22	Threaded rod	4	200202
23	Mesh screen	2	200222
24	Latches	4	200223
25	Acorn nut	8	200504
26	#8 self-tapping screw (for breather)	4	651
27	#10 screw	20	200506
28	#10 flat washer	20	200508
29	Keps nuts	20	200509
30	#10 shoulder screw	12	200510
31	#10 nylon insert lock nut	12	200511
32	1/4" flat washer (for threaded rods)	4	200512
33	Disposable red protective cover	4	300316

Drum Assembly Layout

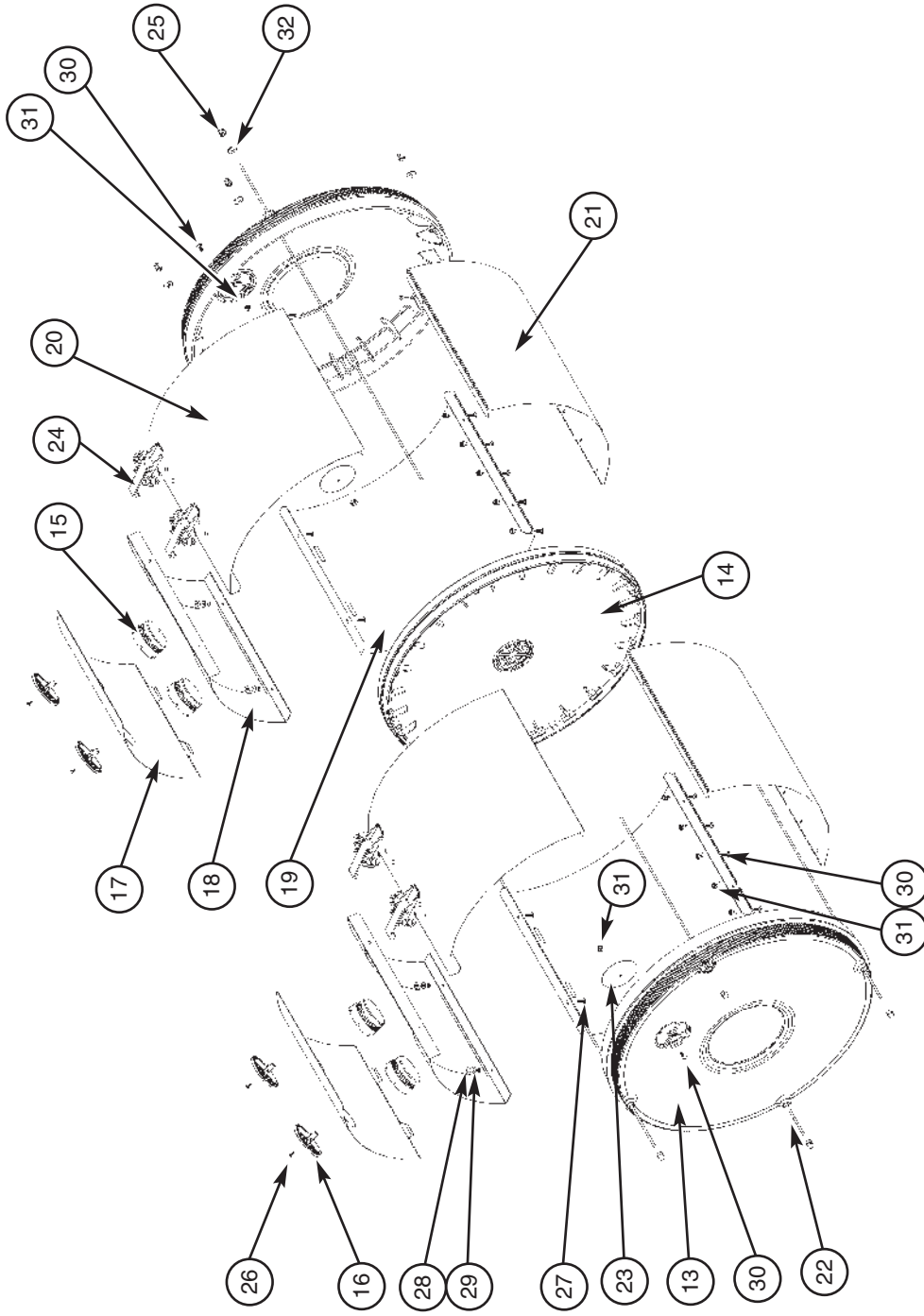

KEY #	DESCRIPTION	QTY	PART #
13	End cap	2	200204
14	Divider	1	200201
15	Breather cap	4	200220
16	Breather screen	4	200221
17	Door	2	200207
18	Door opening, 2nd panel	2	200203
19	Drum 1st panel	2	200216
20	Drum 3rd panel	2	200211
21	Drum 4th panel	2	200224
22	Threaded rod	4	200202
23	Mesh screen	2	200222

KEY #	DESCRIPTION	QTY	PART #
24	Latches	4	200223
25	Acorn nut	8	200504
26	#8 self-tapping screw (for breather)	4	651
27	#10 screw	20	200506
28	#10 flat washer	20	200508
29	Keps nuts	20	200509
30	#10 shoulder screw	12	200510
31	#10 nylon insert lock nut	12	200511
32	1/4" flat washer (for threaded rods)	4	200512
33	Disposable red protective cover	4	300316

Step 16

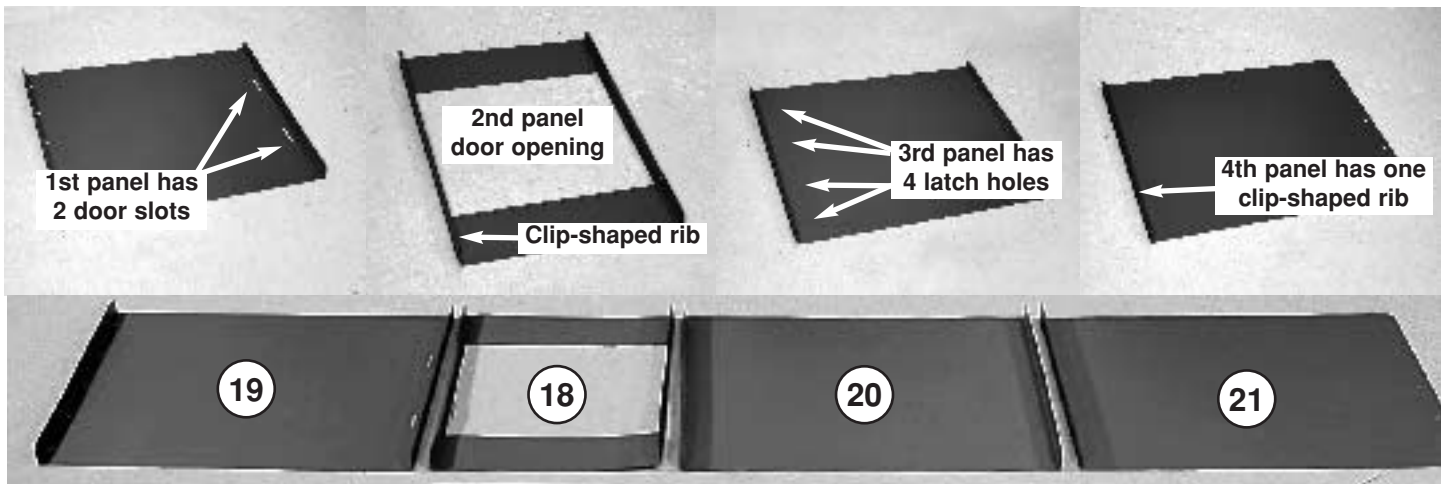

There are two different types of ribs on the panels: one rib is straight, the other is clip-shaped. Place panels on a flat ground surface with the ribs facing up, in the following order:

The two slots of the **drum 1st panel** (key #19) should be next to the door opening (key #18). The clip-shaped rib of the 2nd panel (key #18), **door opening**, should face the 1st panel. The 4 latch holes of the **drum 3rd panel** (key #20) should be next to the flat rib of the 2nd panel. The clip-shaped rib of the **drum 4th panel** (key #21) should be next to the drum 3rd panel.

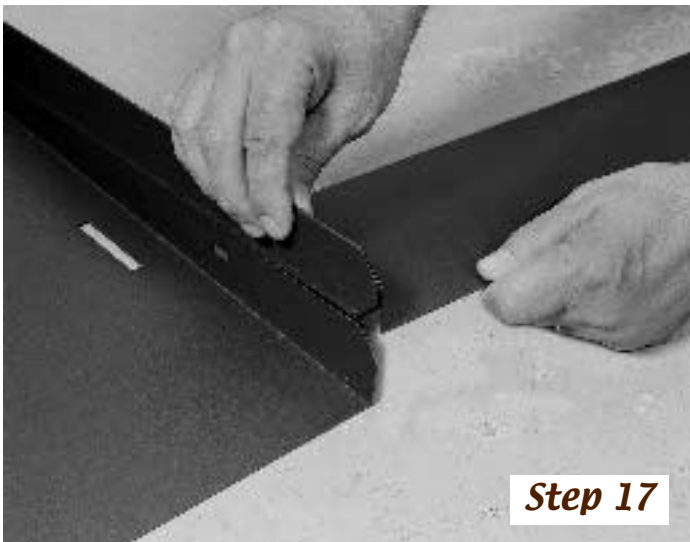

Step 17

Place the drum's 1st panel in a position where the straight rib is facing the door panel's clip-shaped rib. Align outside edges to align holes. Slide the clip-shaped rib of the door panel over the straight rib of the drum's 1st panel, matching up the holes. If necessary, tap into place with a hammer or rubber mallet.

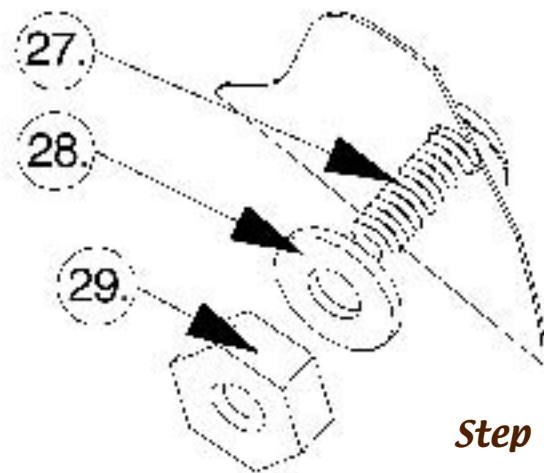

Step 18

Fasten panels using screw (key #27), flat washers (key #28), and keps nut (key #29). Tighten screws using 3/8" wrench and a flat head screwdriver.

Step 19

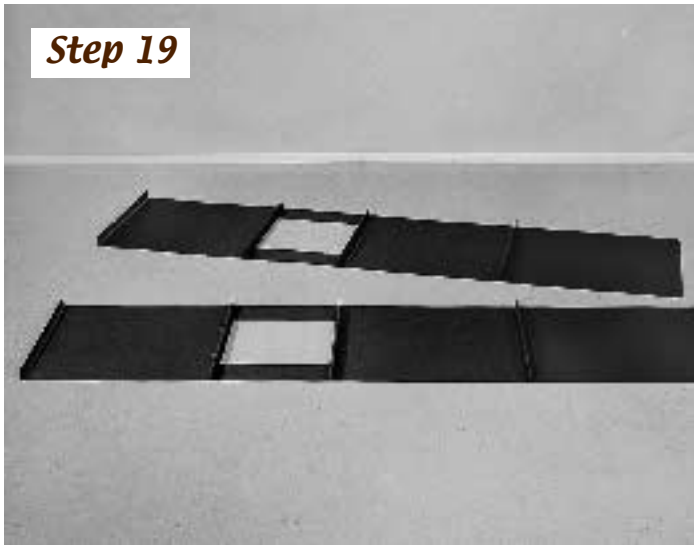

Attach 3rd and 4th panels the same way to complete the first chamber assembly. Assemble the sheet metal panels for the second chamber using the same procedure.

Step 20

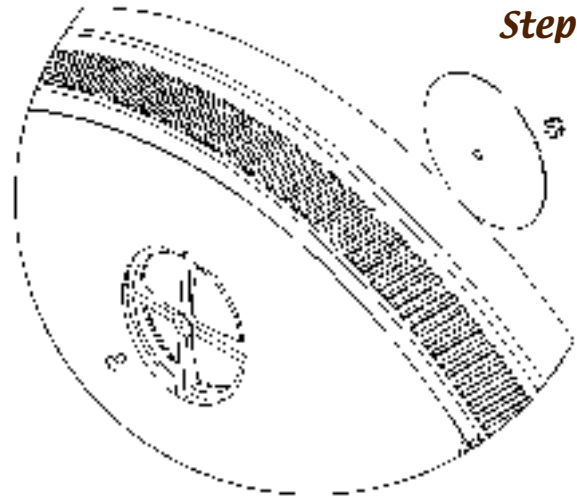

Position mesh screen (key #23) onto the vent hole of the end cap. Affix it using the #10 shoulder screw (key #30) and the #10 locking nut (key #31). Repeat this step with the second end cap.

Step 21

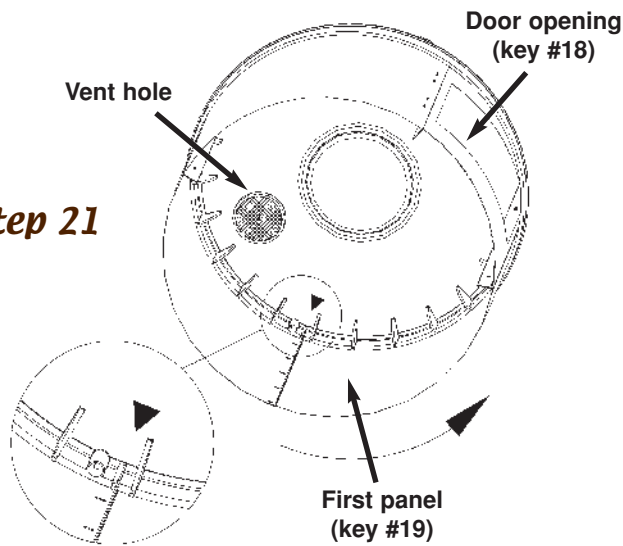

Correct assembly of the body of the first chamber is very important. Beginning at the arrow located inside the end cap, position the rib of the 1st panel (key #19) in the alignment slot. Bend the panels counter-clockwise with ribs inside (the vent opening in the end cap should be across from the door opening, 2nd panel (key #18).



Step 22

Continue to fit the edge of the sheet metal into the opening formed by the inside edge of the end cap and vertical ribs to form the chamber. Overlap the last joint and align the slots. Fasten the last joint using shoulder bolts (brass colored, key #30), nylon insert lock nuts (key #31), Phillips head screwdriver and 3/8" wrench.



Step 23



Step 24

! SAFETY WARNING !

DO NOT TIGHTEN BOLTS - THEY SHOULD SPIN FREELY! SLOTS WILL ACCOMMODATE THE EXPANSION OF MATERIAL DURING TEMPERATURE CHANGES

To attach the door latch (key #24), make sure that the hook part of the latch is pointing up towards the door panel.

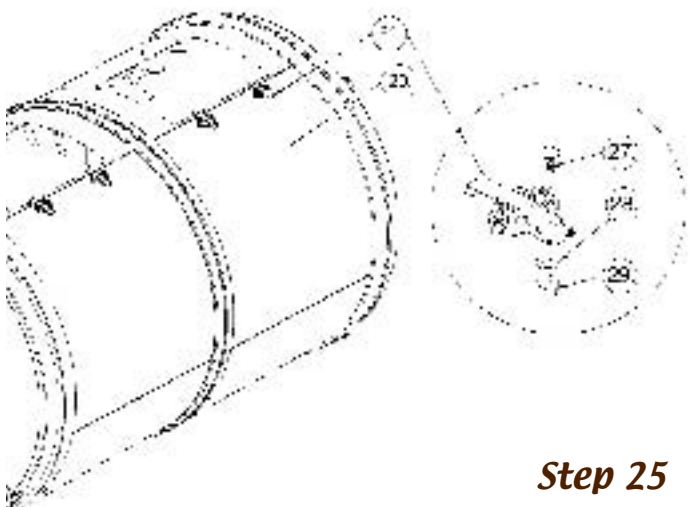

Step 25

Find the two sets of mounting holes on the drum's 3rd panel (key #20) of the first chamber. Attach latches (key #24) to the panel using screws (key #27), flat washer (key #28) and keps nut (key #29), as shown.



Step 26

Place the four threaded rods inside the sheet metal chamber, and into the four round openings found in the end caps.

! SAFETY WARNING !

USE CARE IN HANDLING THE THREADED RODS. BE SURE TO USE THE DISPOSABLE RED PROTECTIVE COVERS FOR YOUR SAFETY IN ASSEMBLING THE COMPOSTER.



Step 27

The divider has the words “DOOR” printed on the inside. Line up the words with the door opening panel. Pick up the divider and guide it so the threaded rods slip through the four openings in the divider.



Step 28

Fit the rim of the divider over the open edge of the sheet metal chamber, tapping to secure in place.

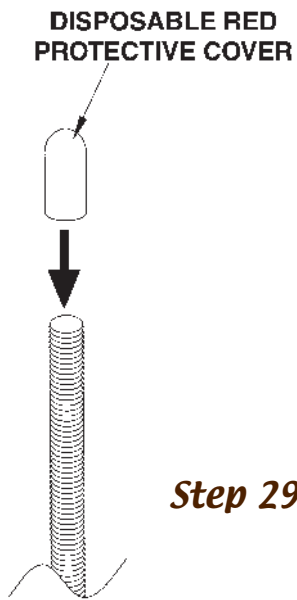

Step 29

Place the disposable red protective covers (key #33) on one end of each threaded rod.



Step 30

Holding the threaded rods and the end of the chamber, tilt the chamber on its side. Thread an acorn nut onto the exposed thread on the outside of the end cap. Repeat this step with all four threaded rods.



Step 31

Holding the threaded rods and the end of the chamber, lift the chamber to rest on the end cap once more.



Step 32

Pick up the sheet metal assembly of the second chamber and place it on top of the divider to align with the door of the first chamber.



Step 33

Bend the assembly with the ribs inside and fit the edge of the sheet metal into the opening formed by the inside edge of the divider and the vertical ribs. Door openings should be located side by side.



Step 34

Overlap the last joint and align the slots. Fasten the last joint using shoulder bolts (brass colored, key #30), nylon insert lock nuts (key #31), Phillips head screwdriver and 3/8" wrench.

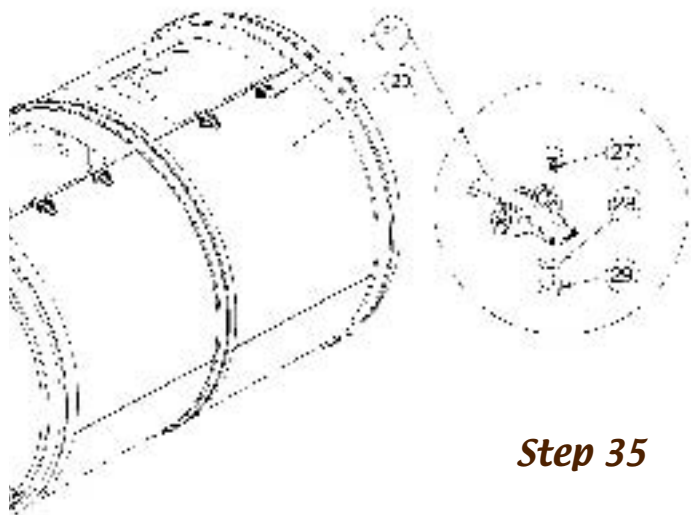

Step 35

Find the two sets of mounting holes on the drum's 3rd panel (key #20) of the second chamber. Attach latches (key #24) to the panel using screws (key #27), flat washer (key #28) and nut (key #29), as shown. Make sure that the hook part of the latch is pointing up towards the door panel.

DISPOSABLE RED PROTECTIVE COVER

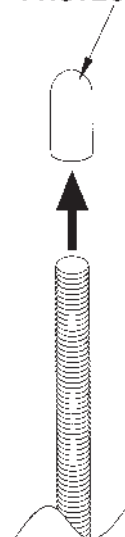

Step 36

Remove the disposable red protective covers from the end of each threaded rod and discard.



Step 37

Position the second end cap over the open end of the drum assembly, so the four round openings align with the four threaded rods, and making sure that the vent hole lines up with the vent hole in the other end cap. Fit the end cap rim over the edge of the sheet metal assembly, making sure that the threaded rods slip through the end cap holes.



Step 38

Place 1/4" flat washer (key #32) over each threaded rod and thread an acorn nut (key #25) onto the end of each rod. Tighten acorn nuts using 7/16" socket wrench.



Step 39

On the support frame, check axle rod gears and middle wheels; be sure that pins are inside of the pin openings of the gears, and that the wheels are in the middle of the axle rods.

Step 40

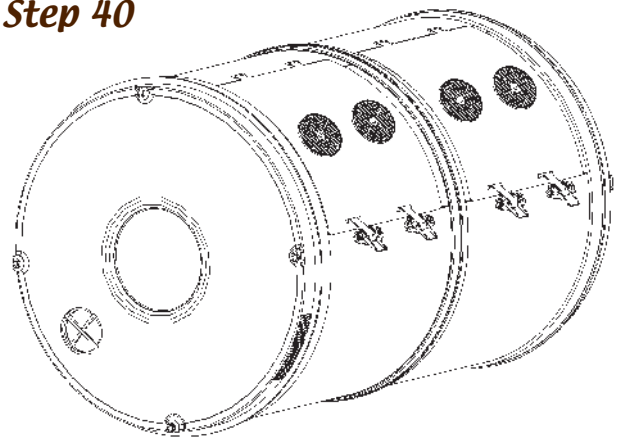

Check the door position before placing the drum on the bottom support frame. The door openings should be on the same side of the bottom frame as the handle, and latches should be on the bottom part of the door opening.

! SAFETY WARNING !

COMPOSTER DRUM IS VERY HEAVY - BE CAREFUL WHEN LIFTING. AT LEAST TWO PEOPLE ARE NEEDED TO LIFT DRUM AND POSITION ON SUPPORT FRAME

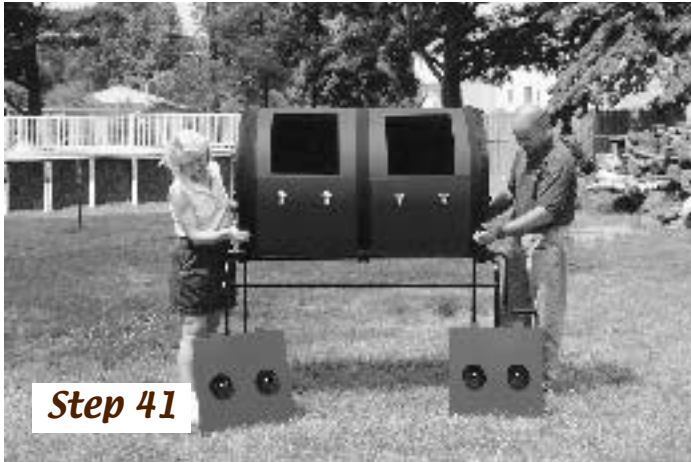

Lift the drum assembly and position on the bottom frame. Adjust gears and middle wheels so that gear teeth mesh with the corresponding end cap teeth, and the middle divider edge fits into the middle wheel groove.

Position the breather cap (key #15) on the inside of the door (key #17), over the breather screen. Place the tip of the cap's boss inside the hollow part of the screen's boss. Hold breather cap and attach these two parts with self-tapping screw using Phillips head screwdriver. Apply some pressure on the screw head to start thread cutting operation. Repeat this step and assemble breathers at all four locations.

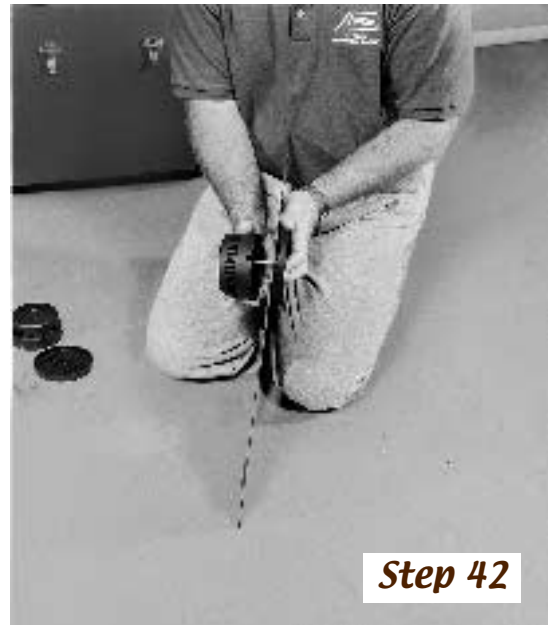

Put self-tapping screw (key #26) into the cavity in the middle of the breather cap. Be sure that the screw's tip is coming out of the hole. Place the breather screen (key #16) on the front side of the door, covering the round opening.

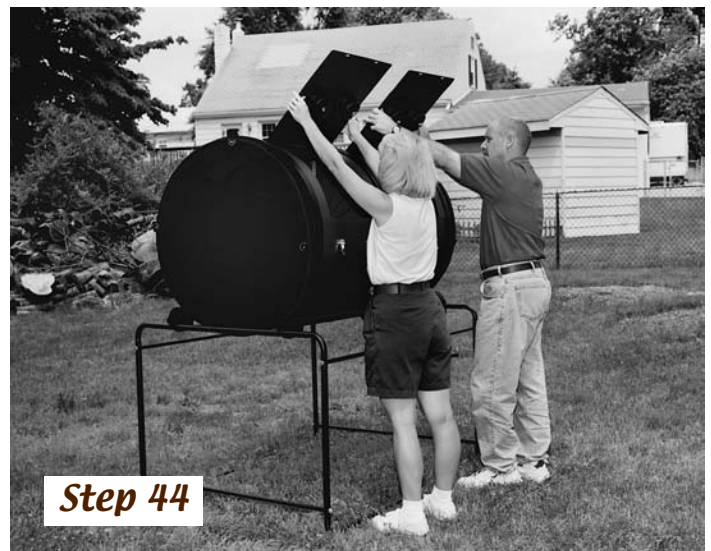

Hold door horizontally and fit door hooks through the openings above the door panel. Close the doors on the drum to cover door opening and check the position of the breather screens.



Close door using latches.

✔✔✔
Your Compost-Twin is now completely assembled! Please read operating instructions before use.

TO REMOVE DOOR:

Step 46

1. Unlatch both latches
2. Open door slightly
3. Slide door up into the drum and rotate.
4. Pull to remove door.
5. Do not bend the door hooks while removing the door.

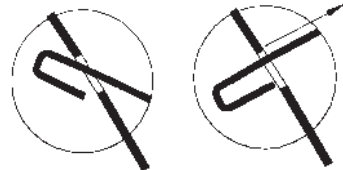
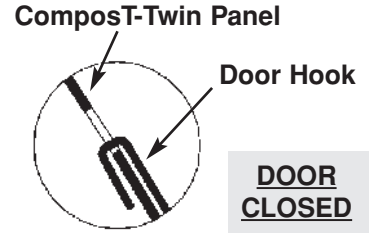
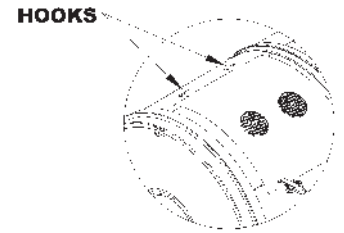

To open, slide door up and rotate - then pull to remove

Maintenance Instructions

After emptying finished compost from a chamber, rinse the inside thoroughly with a garden hose. Occasionally, check the breather screens in the doors to make sure they do not become clogged.

Do not use any chemicals or chemically-based products in the Compost-Twin. Chemicals are corrosive to the galvanized steel drum

During the winter months, if you are not adding materials to your Compost-Twin, you may wish to cover the unit with a composter cover (item #201104)* or tarp for additional protection.

At the beginning of each season, be sure to:

- ✔ Lubricate the four axle rod guides with a wheel bearing-type grease.
- ✔ Check all screws and bolts for tightness.

* available from your local Authorized Mantis Dealer





How to use your new Compost-Twin



Step 48

Fill the first drum with your mix of organic leftovers and yard scraps. For the fastest composting, fill the chamber at least 2/3 full. See the next section for more information on getting the right mix of materials.



Step 49

If you want to, add compost activator (item #201100*) to speed up the decomposition process. Close the door, and do not disturb this chamber. When you have more throwouts to compost, just begin filling the second drum.



Step 50

Once a day, turn the handle to rotate the Compost-Twin barrel about five times. When the tumbler mixes and aerates your material, it builds up a heat core for fast decomposition.



Step 51

You can use a thermometer (item #201101*) and a moisture meter (item #201103*) to check how your batch is "cooking"!

** available from your local Authorized Mantis Dealer*



Step 52

In about two weeks, open, empty, and enjoy the first chamber of finished compost. Be sure to remove the door before turning the barrel and emptying the compost chamber.



Step 53

Now, you can use this chamber for your daily scraps and let the second chamber finish the process of decomposition.

The right mix of materials

Keeping the right ratio of carbon to nitrogen is an important factor in successful composting. Ideally, the mix should be:

30 parts carbon to 1 part nitrogen

A 30:1 mixture breaks down fast (“hot” compost); a different ratio may take several months to finish (“slow” composting).

Shredding or breaking up coarse materials will also speed up decomposition. Use any of the materials on the following page for composting, just be sure to maintain the proper C/N ratio.



Step 54

Carbon

Carbon-rich materials are generally brown or yellow and dry. These include:

- Fallen leaves
- Dried plant prunings like spent annuals and perennials
- Wood ashes
- Straw or hay
- Shredded black & white paper
- Wood shavings
- Sawdust

Nitrogen

High-nitrogen “green” materials are also essential; without them, your compost won’t heat up. Nitrogen enables the micro-organisms to break down the carbon materials. For nitrogen, use:

- Fresh leafy prunings from flowers, hedges and shrubs
- Over-ripe fruit and vegetables
- Fresh grass clippings
- Salad scraps from the kitchen
- Coffee grounds & tea bags
- Egg shells (rinsed & crushed)
- Hair trimmings
- Fresh farm animal manure

Do not add

- Charcoal or coal ash
- Meat or dairy-related materials or shortenings
- Bones, fat or meat
- Pet droppings
- Pesticide-treated plants and grass clippings
- Pressure-treated wood scraps and sawdust
- Poison sumac and poison ivy
- Grain-derived foods



Using your compost

No gardener ever suffered from having a surplus of compost. Well-finished compost can be used at any time, in any season, and in any amount. Here are a few ways you'll enjoy a never-ending supply of compost:

Dig it into the top 4" of vegetable and flower beds in spring. This will establish a good humus level and mineral balance in your soil and provide the nutrients that your plants need. Later, in mid-season, mix compost with soil as a side dressing along vegetable rows or along flower plants.

In established plantings of perennials, where you want to condition the soil and increase fertility without uprooting the plants, work compost liberally into the top 4" of soil.

Compost also makes a fine mulch. In spring, spread a 3" to 4" layer around trees, shrubs, perennials, fruit trees and berries. The mulch will prevent soil moisture from evaporating, suppress weeds, and supply nutrients and humus as it slowly works into the soil.

Lawns also benefit from compost. With a Mantis Tiller, work 1" or more of compost into the soil before seeding a new lawn (or before repairing a patch of old lawn). To help soil organisms thrive, you can top-dress an established lawn with up to 1/2" of compost. If you are using a spreader, be sure to screen the compost first.

Screened compost also makes an excellent potting soil for houseplants as well as potted patio plants. Mix one part compost to three parts rich soil, and top-dress with an inch of compost. When you water the container, the nutrients will be carried down into the soil from the top-dressing.



***Once you start making compost,
your garden will thrive as never before!***

Troubleshooting Tips

Sometimes things go wrong - even with composting. Most composting problems stem from a lack of moisture, too much moisture, a nitrogen imbalance, or poorly managed food scraps. Fortunately, all of these problems have a fairly simple solution. Below you will find a number of commonly encountered symptoms, their causes and their cures.

<i>Problem</i>	<i>Cause</i>	<i>Solution</i>
Bad odor (like rotten eggs or spoiled food)	Inappropriate food scraps	Remove and discard any improper materials (meats, dairy, etc.)
Bad odor (strong ammonia, pond scum)	Anaerobic pile	Turn materials, mixing in dry leaves, straw or wood chips. Check the breather caps in the doors for proper drainage.
Insect pests	This is not necessarily a problem.	Not all insects in a compost pile are “pests”; the compost ecosystem includes a host of helpful invertebrates, including millipedes, centipedes, worms, ants - even snails and slugs, among others.
Insect pests	Too dry, not mixed properly	Make sure food materials are thoroughly mixed in. Hot piles will destroy or deter most insects, such as grubs and other larvae (maggots). Moisten pile if necessary; moist piles deter bees and wasps. Wood chips and woody materials taken from rotted wood piles or municipal mulch piles may contain termites and/or carpenter ants.
Pile not breaking down	Insufficient nitrogen	Add grass, manure, kitchen scraps, or other natural nitrogen sources.
Pile not breaking down	Pile is too dry	Add water, turn chamber, and check moisture level until pile is moist, but not wet; should feel like a sponge throughout.
Pile not breaking down	Poor aeration	Start turning and mixing materials more often.
Pile heats up, then stops	Poor aeration	Hot piles need lots of fresh oxygen; turn materials as pile starts to cool down. It might be necessary to add an additional nitrogen source periodically.

Notes

LIMITED WARRANTY INFORMATION FOR THE MANTIS COMPOST-TWIN



MANTIS extends only to the original consumer purchaser a limited warranty against defects in materials and workmanship for a period of two years from date of purchase. This warranty covers all portions of the MANTIS ComposT-Twin.

MANTIS will repair or, at its option, replace any defective part or parts of the product free of charge. In the event of a defect or malfunction, the purchaser must return the product to an authorized MANTIS dealer.

MANTIS assumes no responsibility in the event that the product was assembled or used in contravention of any assembly, care, safety, or operating instructions contained in the Owner's Manual; was not used with reasonable care; or was used for other than normal and intended purposes.

MANTIS MAKES NO EXPRESS WARRANTIES OR REPRESENTATION EXCEPT THOSE CONTAINED HEREIN. THE DURATION OF ANY IMPLIED WARRANTY, INCLUDING MERCHANTABILITY AND FITNESS FOR A PARTICULAR PURPOSE, IS LIMITED TO THE DURATION OF THE EXPRESS WARRANTY. MANTIS DISCLAIMS ALL LIABILITY FOR INDIRECT AND/OR CONSEQUENTIAL DAMAGES. SOME STATES DO NOT ALLOW LIMITATIONS ON HOW LONG AN IMPLIED WARRANTY LASTS AND/ OR DO NOT ALLOW THE EXCLUSION OR LIMITATION OF INCIDENTAL OR CONSEQUENTIAL DAMAGES, SO THAT ABOVE LIMITATIONS AND EXCLUSIONS MAY NOT APPLY TO YOU. THIS WARRANTY GIVES YOU SPECIFIC LEGAL RIGHTS, AND YOU MAY ALSO HAVE OTHER RIGHTS WHICH VARY FROM STATE TO STATE.

MANTIS
1028 Street Road
Southampton, PA 18966
(215) 355-9700

Specifications, descriptions, and illustrative material in this literature are as accurate as known at the time of publication, but are subject to change without notice.

P/N 200711
©MANTIS 12/03
Printed in USA